

Heteropolymetallic Complexes of 1,1'-Bis(diphenylphosphino)ferrocene (dppf). III*. Comparative Physicochemical Properties of (dppf)MCl₂ (M = Co, Ni, Pd, Pt, Zn, Cd, Hg)

BENEDETTO CORAIN, BRUNO LONGATO, GIANCARLO FAVERO

Centro di Studio sulla Stabilità e Reattività dei Composti di Coordinazione del C.N.R., Via Marzolo 1, I-35131 Padua, Italy

DAVID AJÒ

Istituto di Chimica e Tecnologia dei Radioelementi del C.N.R., Corso Stati Uniti 4, I-35100 Padua, Italy

GIUSEPPE PILLONI, UMBERTO RUSSO

Dipartimento di Chimica Inorganica, Metallorganica ed Analitica, Via Loredan 4, I-35131 Padua, Italy

and F. R. KREISSL

Anorganisch-Chemisches Institut, T.U. München, Lichtenbergstrasse 4, D-8046 Garching, F.R.G.

(Received May 27, 1988; revised August 8, 1988)

Abstract

1,1'-Bis(diphenylphosphino)ferrocene (dppf) metal dichlorides (metal = Co, Ni, Pd, Pt, Zn, Cd, and Hg) are examined as a class of related complexes. Their electronic, infrared, mass, ³¹P NMR, and Mössbauer spectra as well as the HeI and HeII photoelectron spectra of dppf are presented and discussed. Cyclovoltammetric tests in dichloroethane indicate that the ferrocene moiety undergoes a strong stabilization towards oxidation, and the ferricinium derivatives are well characterized in the case of Pd(II) and Pt(II). Differential scanning calorimetric tests reveal that all the complexes are thermally very stable, particularly the Zn(II) and Cd(II) derivatives, which melt without previous decomposition in the temperature range 300–305 °C. Cyclovoltammetric and field desorption mass spectral tests reveal that the [(dppf)MCl₂]⁺ species are stable only when M = Pd, Pt.

Introduction

Interest in the synthesis and chemistry of heterobi- (or poly-) metallic complexes has grown in recent years [1]. In spite of the fact that the scientific motivations for such efforts are diverse, a unifying feature is the assumption that two or more, adjacent, non-directly bonded, different metal centers should be able to disclose novel cooperative chemical properties.

1,1'-Bis(diphenylphosphino)ferrocene (dppf) [2] appears to be a remarkably simple metal-bearing

ligand, suitable for the preparation of bi-, tri-, and tetra-metallic complexes such as those of type I, II, and III of Scheme 1 in which, interestingly, the acceptor metal atom may exhibit quite variable electronic properties [3].

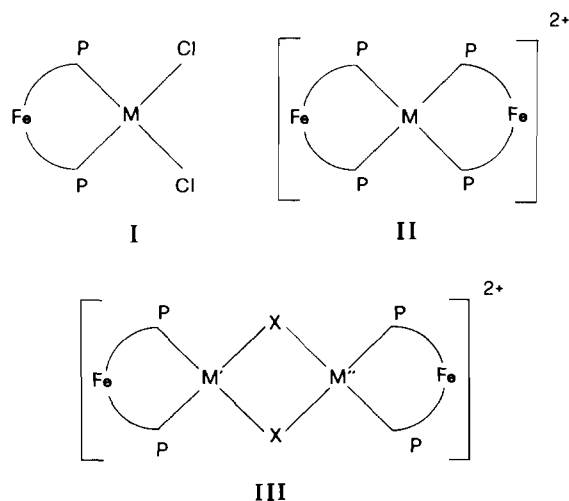

Scheme 1.

We came across dppf [4] while searching for new ligands able to afford novel *cis*-platinum and *cis*-palladium complexes of potential pharmaceutical interest [5] and decided to undertake a systematic investigation on complexes of types I–III. The aim was to look for trends in their basic physicochemical features, with particular attention to their solvolytic behavior [6] and to their reactivity with biomolecules [5].

We report here on comparative properties of complexes with general formula (dppf)MCl₂ (**1**) (M = Co,

*Part I of this series is ref. 4; part II is ref. 8.

TABLE 1. Physicochemical Data for the (dppf)MCl₂ Complexes (1a–g)

Complex (M)	λ_{\max} (nm) ^a (ϵ (M ⁻¹ cm ⁻¹))	μ (BM)	$\nu(\text{M}-\text{Cl})^{\text{b}}$ (cm ⁻¹)	$\delta(^{31}\text{P NMR})^{\text{a}}$ (ppm)	Melting point ^c (°C)	M ⁺ (%) ^d (t.i.s. (°C)) ^e	ΔH_{m} (kcal/mol)
FeCp ₂	441(99)			-16.82	181		10.8
dppf	441(200)				312	0.8(290)	22.1
1a (Co)	450(325); 606(600); 636(800); 737(470)	4.5	305; 330		280	0.1(250)	n.d. ⁱ
1b (Ni)	405(3000); 618(300); 848(230)	3.7	297; 330	+34.00	284	0.0(250)	n.d. ⁱ
1c (Pd)	463(650)		290; 310	+13.06 ^f	348	10.0(260)	n.d. ⁱ
1d (Pt)	429(260)		291; 317	-21.34	305	0.0(160)	13.3
1e (Zn)	450(160)		285; 312	-8.68	300	0.0(160)	17.3
1f (Cd)	444(210)		270 ^g	+19.18 ^h	252	0.0(170)	n.d. ^m
1g (Hg)	443(230)		240; 280				

^a In CH₂Cl₂ at 27 °C. ^b In nujol mulls. ^c Determined by DSC measurements. ^d Percentage of the molecular peak with respect to the base one. ^e Temperature of ion source for EI mass spectrometric measurements. ^f $J(\text{Pt}-\text{P}) = 3769$ Hz. ^g Composite band. ^h $J(\text{Hg}-\text{P}) = 4108$ Hz. ⁱ Not determined owing to a following and partially overlapping exothermic event in the molten phase (see text).

a; Ni, b; Pd, c; Pt, d; Zn, e; Cd, f; Hg, g) (see Table 1), most of which have been already prepared, but only partially characterized (1a [7a], 1c [7b], 1d [4], 1g [7c]). 1e and 1f are new adducts.

Results and Discussion

General Features and Solid State Structure

Most of the physicochemical properties reported and discussed in this paper are collected in Table 1.

The X-ray single crystal structures of 1c [7b] and 1d [4] reveal that these complexes are monomeric species, in which the metal atoms are surrounded by a planar ligand arrangement. X-ray data [8] indicate that in 1b the Ni(II) ion is tetrahedrally coordinated to dppf and two chlorine atoms, so justifying the observed magnetic moment of 3.7 BM. The magnetic moment (4.5 BM) of 1a is consistent with an analogous coordination in the solid state. For complexes 1e–g, no direct information on their solid state structures, except the infrared data, are available. In view of the well established tendency to tetrahedral coordination of Zn(II), Cd(II), and Hg(II), it seems also reasonable to propose for them a coordination similar to that of 1a and 1b. The far infrared data for all the complexes 1 (see Table 1) agree with the proposed mutual position of the two chloride ions. In fact, all complexes 1 show the expected pair of M–Cl bands in the appropriate spectral range [9].

Electronic, ³¹P NMR Spectra and Stability in Solution

All complexes are at least moderately soluble in CH₂Cl₂, where ³¹P NMR and optical spectra appear unaltered for several days. Solutions of 1a–1g obey Lambert-Beer's law in 10 to 50 times concentration range; the ϵ figures reported in Table 1 are the average of three differently concentrated solutions. In the 405–465 nm range, all the complexes exhibit a well detectable band that we attribute to an e_{2g}–e_{1g} transition in the ferrocenyl moiety [10], by analogy with the 441 nm band of ferrocene. In addition to this feature, 1a and 1b display also typical ligand field bands attributable to tetrahedral d⁷–d⁸ dihalidobis-phenylalkylphosphino coordination spheres. The presence of this single charge transfer band for complexes 1c–1g is in agreement with the presence of square planar {MCl₂P₂} moieties (M = Pd, Pt; P = substituted phosphine) and tetrahedral chromophores (M = Zn, Cd, Hg). Therefore, the data as a whole suggest the presence in solution of 'simple' species of type I (see Scheme 1).

Dppf exhibits an absorption band that is energetically identical to that shown by ferrocene, being the relevant ϵ just twice as large as in the unsubstituted, certainly symmetric, organometallic chromophore. The λ value of the charge transfer band is fairly

sensitive to the nature of the metal chloride bonded to the two diphenylcyclopentadienyl ligating functions. Similarly, the ϵ values also appear to be generally sensitive to the nature of the MCl_2 moiety, but the changes in λ_{max} and ϵ do not seem to obey any horizontal or vertical trend. For instance, $(dppf)CoCl_2$ and $(dppf)NiCl_2$, both tetrahedral complexes with metal centers of quite similar size, display λ_{max} and ϵ figures non-related to the expected similarity of the geometric and electronic features of the dppf chromophore. Analogous considerations can be made for the 1-c/1-d pair. We are presently unable to offer any interpretation of the apparently erratic behaviour of this band.

The $^{31}P\{^1H\}$ NMR spectra of complexes 1c–1g were obtained in CH_2Cl_2 solution at room temperature and the results are collected in Table 1. With the exception of the cadmium complex, the ^{31}P resonances appear as sharp singlets (for all the complexes), flanked by satellites in the case of the platinum and mercury derivatives. The observed chemical shifts and coupling constant values are in the expected range for mononuclear complexes containing a chelating diphosphine ligand [11a,b]. Furthermore, the decrease of the coordination chemical shift on going from the Zn to the Hg complex parallels that observed for other related monodentate phosphine (PCy_3 [11c] and $PHCy_2$ [11d]) complexes. The ^{31}P NMR spectrum of $(dppf)CdCl_2$ exhibits a broad singlet ($\Delta\nu \approx 180$ Hz at 27 °C) at $\delta = -8.68$, probably due to a phosphine exchange occurring at room temperature. Although the temperature effect on this chemical process was not further investigated, this result clearly indicates a lower stability of the cadmium derivative in the class of the studied MCl_2 -(dppf) complexes. Moreover, the sharp ^{31}P resonance, together with the presence of well resolved ^{199}Hg - ^{31}P satellites found for the 1g complex, confirms previous observations indicating a mercury–phosphorus bond stronger than the cadmium–phosphorus one in the halide phosphino complexes of these metals [11e]. All the data confirm the stability of complexes 1 in CH_2Cl_2 solution and they are in agreement with a structure of type I. Particularly significant in this sense is the $J(Pt-P)$ value, 3769 Hz, as expected in a platinum(II) planar complex in which a chloride ligand is *trans* to a phosphine ligand. This datum rules out the possible existence of oligomeric structures in which the *cis* nature of the $\{PtCl_2\}$ moiety should be lost. This circumstance would have prevented the utilization of 1d as a model for a new possible class of biologically active *cis*-platinum complexes, that is under intense investigation in these laboratories [5a, b, 6].

Photoelectron Spectra

In order to shed light into the electronic structure of the dppf ligand in complexes 1 and to try to

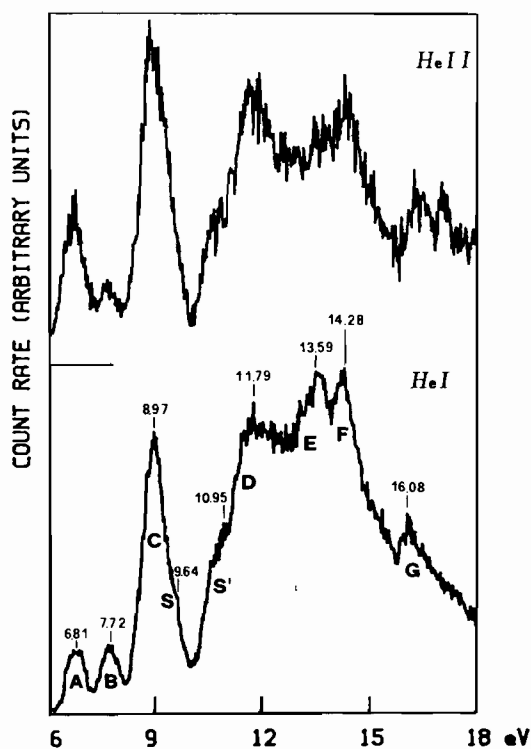

Fig. 1. He I and He II spectra of dppf ($T = 421$ K).

rationalize the spectrophotometric data, we undertook a photoelectron (PE) investigation. The PE spectra of dppf are depicted in Fig. 1. The assignment of these spectra is based on the comparison with those of ferrocene [12, 13] and aromatic phosphines [14]. The ionization energy (IE) value of the band A in the dppf spectra is very close to that of the first band of ferrocene (6.88 eV) [13], that originates from the $^2E_{2g}$ state [12]. Band B significantly decreases in intensity under He II radiation with respect to A. Therefore, B cannot be associated with the second band of ferrocene that derives from the $^2A_{1g}$ state, since the latter slightly increases its relative intensity (this has been ascribed to the higher 'd' character of $^2A_{1g}$ with respect to $^2E_{2g}$). Consistently, A should include both the first and the second ionization (the separation between them being significantly lower than in ferrocene). Band B is assigned to the diphenylphosphine moiety; as a matter of fact, the first band of triphenylphosphine (vertical IE) lies at 7.88 eV [13], to be compared to 7.72 eV of dppf. The broad band C with its shoulder S on its lower IE side (8–10 eV) apparently includes ionizations from both ferrocene and diphenylphosphine groups, while the shoulder S' has its counterpart (10.90 eV) in the PE spectra of diphenylphosphine or triphenylphosphine.

According to these assignments, the IE of the HOMO is very similar in ferrocene and dppf. This re-

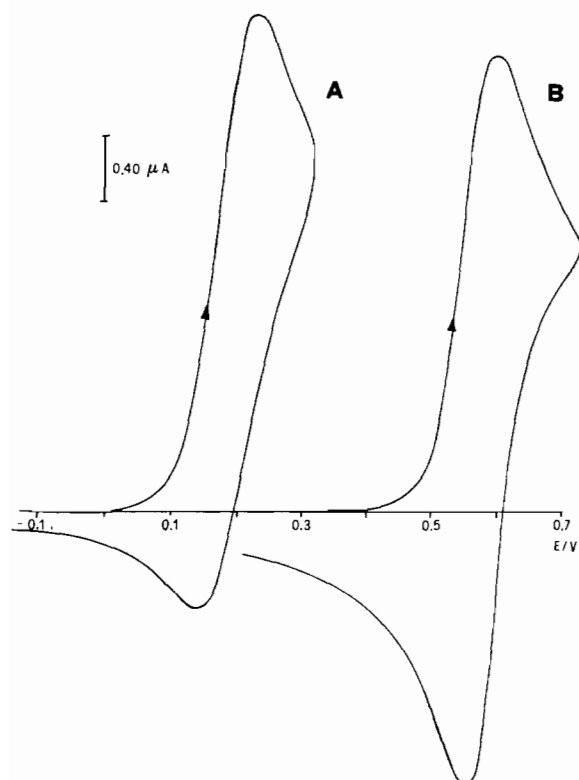

Fig. 2. Cyclic voltammogram (0.3 V/s) for oxidation of 3.6 mM dppf (A) and (dppf)PtCl₂ (B) in 1,2-dichloroethane, 0.2 M tetrabutylammonium perchlorate, at a Pt electrode {V vs. [FeCp₂]⁺/FeCp₂}.

sult can somehow be related to the substantial identity of the λ_{\max} of ferrocene and dppf (see Table 1), but full understanding of this datum requires further investigations. On the basis of the encouraging results obtained on the solid state thermal stability of complexes **1**, as will be described later, we attempted to examine their PE spectra, but in no case was the concentration of the molecular species in the gas phase (before decomposition on heating) high enough for recording reasonable PE spectra.

Voltammetric Behavior and Chemical Oxidation

It is well known that ferrocene FeCp₂ undergoes a highly reversible oxidation process in various organic solvents to give the stable [FeCp₂]⁺ cation. The presence of a diphenylphosphino group on each cyclopentadienyl ring in dppf makes the oxidation of Fe(II) to Fe(III) much more difficult, as shown by the cyclic voltammetric behavior of dppf on a Pt electrode in 1,2-dichloroethane (see Fig. 2a).

It is seen that the ligand undergoes an essentially reversible one-electron oxidation ($E^{\circ} = 0.183$ V versus [FeCp₂]⁺/FeCp₂; $\Delta E_p = 80$ mV) followed by a fast chemical reaction (EC mechanism). Indeed, the cathodic to anodic current ratio, ip_c/ip_a , is less than

1 and increases with the scan rate, 1 being approached at a rate of 3 V/s. For **1c** and **1d**, on the contrary, a simple reversible one-electron cathodic-anodic system is observed (see Fig. 2b) at much higher potential values ($E^{\circ} = 0.573$ V versus [FeCp₂]⁺/FeCp₂; $\Delta E_p = 60$ mV). Complexes **1a**, **b**, **e** and **f** exhibit irreversible or ill-defined anodic peaks owing to interferences by product adsorption on the electrode and/or by contamination of the electrode by decomposition products. In the case of **1g**, the voltammetric pattern is quite similar to that given by uncoordinated dppf (EC mechanism), but the rate of the chemical step is much higher ($ip_c/ip_a \ll 1$ at 3 V/s). The observed lack of coupled cathodic peak after the oxidation of **1a**, **1b**, **1e**, **1f**, **1g** points to a prominent instability and lability of [(dppf)MCl₂]⁺ species, *i.e.* complexes of the [dppf]⁺ ligand. The observed instability of the adducts of MCl₂ with [dppf]⁺ may be accounted for on considering that the phosphorous → metal bond, which is purely σ in character for M = Zn, Cd, and Hg, is expected to undergo a strong weakening effect in these complexes as expected from the positivation of the ferrocenylphosphino ligand. The consequent cleavage of the P–M bonds leads to free [dppf]⁺, which is found to be in its turn particularly unstable, thus accounting for the absence of any cathodic peak (eqn. (1)).

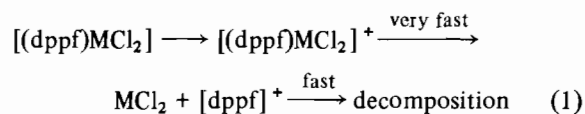

This rationale explains why the [(dppf)MCl₂]⁺ species are stable for M = Pd, Pt. In fact, in these cases it can be expected that the weakening of the P–M bonds upon dppf oxidation may be compensated by M → P backbonding, which is possible in square-planar Pd(II) and Pt(II) complexes.

We attempted the chemical oxidation of **1c** and **1d** by utilizing the strongly oxidizing agent NOBF₄ in 1,2-dichloroethane. In both cases the attempt was successful, but the green microcrystalline paramagnetic products, [(dppf)MCl₂]BF₄, could not be obtained analytically pure (see 'Experimental' for details and essential spectral data). The oxidized species are soluble and stable in nitromethane. In this solvent the $e_{2g}-e_{1g}$ band for the Pt complex is found at 470 nm ($\epsilon = 190$) to be compared with 429 nm ($\epsilon = 260$) observed for **1d**.

Mössbauer Spectra

The Mössbauer parameter of ferrocene, dppf, and of the relevant complexes are collected in Table 2 and the spectra of dppf and of **1c** are depicted in Fig. 3.

As shown by the X-ray crystal structure [8], the introduction of a diphenylphosphino group in each cyclopentadienyl ring of the ferrocene molecule results in the blocking of the two rings in a staggered

TABLE 2. Mössbauer Parameters for Ferrocene, Diphenylphosphino Ferrocene and (dppf)MCl₂ Complexes

Species	δ (mm s ⁻¹)	ΔE_Q (mm s ⁻¹) ~ 293 K	Γ (mm s ⁻¹)	δ (mm s ⁻¹)	ΔE_Q (mm s ⁻¹) 77 K	Γ (mm s ⁻¹)
ferrocene	0.44	2.37		0.53	2.42	
dppf	0.42	2.30	0.25	0.52	2.33	0.31
(dppf)CoCl ₂	0.46	2.34	0.22	0.55	2.34	0.33
(dppf)NiCl ₂	0.44	2.30	0.21	0.54	2.29	0.27
(dppf)PdCl ₂	0.41	2.21	0.22	0.49	2.21	0.23
(dppf)PtCl ₂	0.41	2.23	0.21	0.50	2.29	0.23
(dppf)ZnCl ₂	0.46	2.36	0.23	0.55	2.35	0.24
(dppf)CdCl ₂	0.41	2.23	0.22	0.51	2.27	0.30
(dppf)HgCl ₂	0.48	2.35	0.22	0.56	2.36	0.25

position with the phosphino residues opposite to each other with the two rings planar and parallel to each other. Consequently, the isomer shift value remains constant, while (Table 2) a small decrease in the quadrupole splitting is evident. This behaviour is consistent with the fact that the phosphino groups affect the π electron system of the ring without any

significant perturbation on the σ electrons; this influence is maximized by the coplanarity of the rings with the phosphorus atoms, so that the largest orbital overlap is obtained.

The coordination of a metal to the two phosphine groups has an important consequence on the arrangement of the cyclopentadienyl rings, which in turn lowers the microsymmetry around the iron atom. Now the two rings are tilted at an angle of about 6° and are rotated with respect to each other by 180° [4, 7b, 8], so that an eclipsed configuration is achieved. Moreover, the preference of a given metal towards a square-planar or tetrahedral geometry (e.g. **1b**, see ref. 8) may further affect the distortion of the ferrocene moiety. As a consequence, both the isomer shift and the quadrupole splitting values vary according to the coordinated metal. The isomer shift is little affected by the coordination, varying between 0.49 and 0.56 mm s⁻¹, with an average value of 0.53 mm s⁻¹, identical to that of ferrocene. This small range may be related to the tilting of the aromatic ring, or to an influence on the σ electrons exerted by the phosphorus atoms that are now displaced out of the ring plane towards the metal atom. The coordination influence on the quadrupole splitting is more evident. The values now range from 2.21 to 2.36 mm s⁻¹, falling on the two sides with respect to the free ligand, but in any case remaining lower than the ferrocene value. This fact seems to indicate that the electronic and structural variations deriving from the metal coordination are opposite in sign. Consequently, no obvious relation between the quadrupole splitting or the isomer shift values and the ionic or covalent radii or the electronegativity of the various coordinated metals results are apparent so far.

Thermal Behavior under DSC Conditions and Mass Spectrometry

All the investigated complexes are high melting microcrystalline materials; the melting temperatures and related ΔH values are collected in Table 1. Complexes **1** melt in the temperature range 250–350 °C

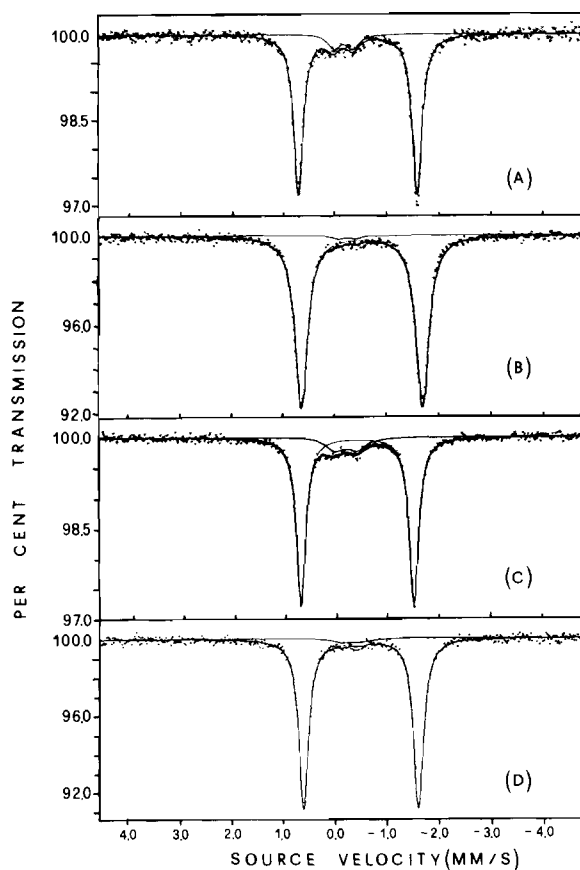

Fig. 3. Mössbauer spectra of dppf at room temperature (A) and at 77 K (B) and **1c** at room temperature (C) and at 77 K (D).

(m.p. of dppf = 181 °C). The DSC profiles of dppf, **1a**, and **1f** display simple, fairly symmetric melting peaks, while those of **1g** and **1e**, but especially of **1b** to **1d**, exhibit also a post-melting exothermic transition, which invariably overlaps with the associated endothermic peak. The different melting behaviours are illustrated in Fig. 4 for **1d** and **1f**.

The exothermic peak in the molten phase is interpreted as due to significant molecular rearrangements occurring just after the lattice disruption. Attempts to imitate this behavior under 'macro' conditions (*i.e.* on a 50–100 mg scale in a test tube) and to characterize the post melting products have failed so far.

The most interesting feature of the thermal behavior displayed by complexes **1** appears to be the remarkable thermal stability exhibited by the Zn, Cd and Hg derivatives of dppf. In fact, the tendency of these metals to produce phosphino complexes is certainly limited, especially for Zn, which is considered a 'hard' Lewis acid. We find that not only ZnCl₂ and CdCl₂ react quantitatively with dppf under mild synthetic conditions to give simple (dppf)MCl₂ adducts, but the complexes appear also to be thermally stable up to about 300 °C. The paucity of preparative and thermal data on phosphino complexes of Zn and Cd makes impossible a thorough analysis of our findings, in particular, an evaluation of their relevance to possible bonding features of dppf.

The high solid state thermal stability of complexes **1** is not paralleled by an easy detection of the molecular mass in the mass spectrum under electron impact (EI) ionization conditions (see Table 1). In fact, in spite of a careful control of the heating conditions in the ion source, the molecular parent peak is just detectable in the case of **1a** and **1b**, and it is well detected only for **1d**. In order to check whether these results can be attributed to an unexpected thermal instability of gaseous M or to the instability of the relevant M⁺(g) species, we utilized a softer ionization mode, *i.e.* the field desorption technique (FD). The results reveal that in all cases but **1c** and **1d** the only important peak is that of the free dppf, M⁺ being easily detectable only for **1c** (25% of the base peak) and the base peak for **1d**. These data reveal therefore that the absence of M⁺ in the EI spectrum of complexes **1** is attributable to the very low stability and to the exceedingly high lability of the molecular ions. On the basis of the quite reasonable assumption that in M⁺(g) species the electron is lost by dppf, the high instability and lability of the ferricinium derivatives parallels that already observed under cyclovoltammetric conditions.

Experimental

Instruments

Infrared spectra: Perkin-Elmer 599B. NMR spectra: Jeol FX90Q.

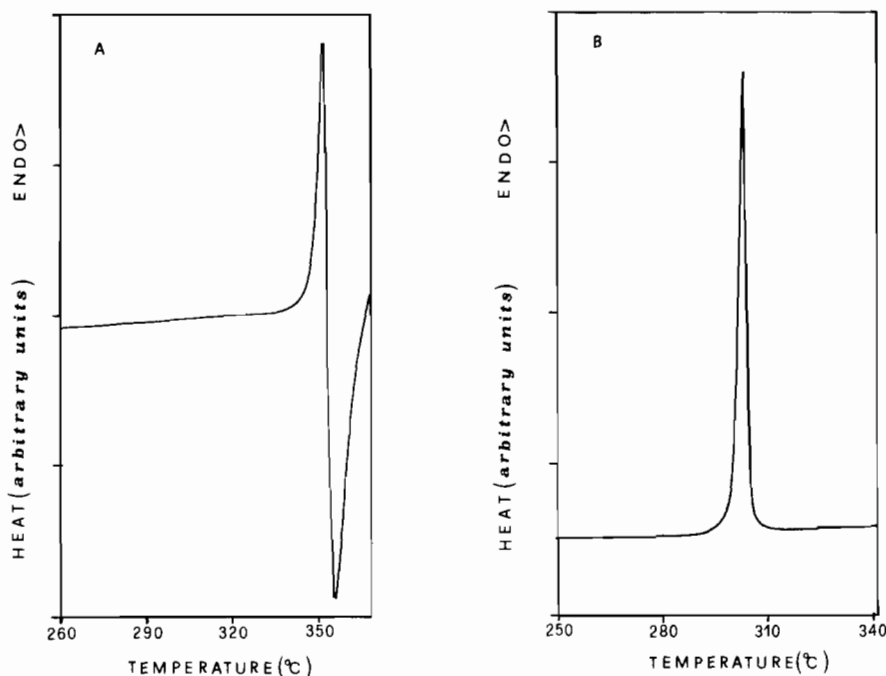

Fig. 4. DSC profiles of **1d** (A) and **1f** (B) (40 °C/min, N₂).

Electronic spectra: Perkin-Elmer Lambda 5. Mass spectra: Varian Mat 311 A. Photoelectron spectra: Perkin-Elmer PS18. Differential scanning calorimetry: Perkin-Elmer DSC4. Mössbauer spectra were obtained at room temperature and 77 K on a conventional constant-acceleration spectrometer, which utilized a room temperature rhodium matrix cobalt-57 source. The spectra were fitted to Lorentzian line shapes by using standard least-squares computer minimization techniques. All spectra consist of a single quadrupole doublet. In our fitting procedure, each component of a quadrupole doublet was constrained to have equal line widths and areas.

Voltammetric measurements were carried out by an AMEL 551 potentiostat modulated by an AMEL 566 function generator. While the recording device was either Hewlett-Packard model 7040 A XY recorder or a Gould Advance mod. 054100 digital storage oscilloscope with analogue output for XY recorders, depending on the scan rate employed. All experiments were performed in 1,2-dichloroethane with 0.2 M tetrabutylammonium perchlorate, using a conventional three-electrode liquid jacketed cell. The working electrode was a planar Pt microelectrode ($\sim 0.3 \text{ mm}^2$) surrounded by a Pt spiral counter electrode. A silver/0.1 M silver perchlorate electrode in acetonitrile was used as the reference electrode.

Magnetic susceptibility values were measured by the Faraday method (Oxford Instruments apparatus equipped with a Cahn 2000 microbalance) at room temperature. Diamagnetic corrections [15] were carried out.

Materials

Solvents and reagents were of reagent grade. NOBF_4 was from Aldrich. $(\text{dppf})\text{HgCl}_2$ was prepared according to ref. 7c.

Complexes **1a**, **1b**, **1e**, **1f** and **1d** were prepared according to the following procedure. The appropriate metal dihalide dissolved in the minimum volume of a 2:1 (v/v) mixture of 2-propanol and methanol is added to a solution of **dppf** (1 mmol) dissolved in 40 cm^3 of hot 2-propanol, under stirring. The mixture is refluxed for 2 h and then left to cool at room temperature. The complexes are obtained as colored microcrystalline analytically pure products which are filtered on gooch filters, washed with a little solvent and dried in vacuum. Yields ranged from 70 to 80%. Colors and elemental analyses (calc. in parentheses) are as follows. **1a** blue: C, 59.42(59.68); H, 4.19(4.13); Cl, 11.05(10.36). **1b** dark green: C, 59.87(59.70); H, 4.15(4.13); Cl, 10.37(10.37). **1e** orange–yellow: C, 59.11(59.13); H, 4.13(4.09); Cl, 10.55(10.27). **1f** orange–yellow: C, 55.32(55.35); H, 3.83(3.83); Cl, 8.60(8.62). **1g** orange–red: C, 49.70(49.45); H, 3.41(3.42)%.

Complex **1c** was prepared by mixing 1 mmol of $[\text{Pd}(\text{PhCN})_2\text{Cl}_2]$ with 1 mmol of **dppf** both dissolved

in 10 cm^3 of benzene. The mixture was stirred for 12 h at *ca.* 20°C . The filtered reddish-yellow microcrystalline powder was washed with a little benzene and dried in vacuum. Red crystals analyzing as $[(\text{dppf})\text{PdCl}_2] \cdot \text{CH}_2\text{Cl}_2$ can be obtained upon slow solvent evaporation from CH_2Cl_2 solutions. *Anal.* Found (calc.): C, 52.05(51.47); H, 3.59(3.70); Cl, 17.40(17.36)%. (Yield = 65%).

Complex **1d** was prepared upon refluxing a suspension of PtCl_2 (1 mmol) in a **dppf** solution (1 mmol) in benzene for 20 h. After cooling, a suspension of **1d** was obtained, which was filtered on a gooch filter and dried in vacuum. Lemon–yellow powder. *Anal.* Found (calc.): C, 49.45(49.78); H, 3.60(3.44); Cl, 8.84(8.64)%. (Yield = 93%). **1d** can be recrystallized from acetone, in which case a clathrate containing one molecule of solvent per Pt atom is obtained.

Oxidation of **1d** by NOBF_4 : **1d** (0.4 mmol) was dissolved in 20 cm^3 of $\text{C}_2\text{H}_4\text{Cl}_2$ under nitrogen, to which solution 0.4 mmol of solid NOBF_4 was added under air exclusion and vigorous stirring. The solution turned gradually into a green suspension from which a green powder could be separated upon filtration. *Anal.* Found (calc.) for $[(\text{dppf})\text{PtCl}_2]\text{BF}_4$: C, 43.81(45.02); H, 2.98(3.11); Cl, 8.73(7.82)%. λ_{max} (nm) in nitromethane ($\epsilon(\text{M}^{-1} \text{ cm}^{-1})$): 652(270); 590(230) sh; 470(190). $\nu(\text{Pt}-\text{Cl}) = 302$ and 326 cm^{-1} (nujol). $\mu = 2.6 \text{ BM}$ (see ref. 16 for the room temperature magnetic moment of ferricinium).

Conclusions

1,1'-Bis(diphenylphosphino)ferrocene (**dppf**) appears to be rather a flexible system, since the two cyclopentadienyl rings can assume different mutual arrangements in **dppf** itself and in different complexes with metal dihalides. Nevertheless, it tends to give simple, monomeric, thermally very stable bimetallic adducts as the consequence of limited conformational freedom of the ligands. Related, but much 'longer' ligands such as 1,1'-bis[dimethyl(2-diphenylphosphino)ethylsilyl]ferrocene [17] give rise in fact to much more structurally complicated adducts with NiCl_2 and NiBr_2 (e.g. dimeric structures and allgonic equilibria).

Acknowledgement

The authors thank Mr F. De Zuane (Istituto di Chimica e Tecnologia dei Radioelementi, C.N.R., Padua) for magnetochemical measurements.

References

- (a) R. M. Bullock and C. P. Casey, *Acc. Chem. Res.*, **20** (1987) 167; (b) L. Gelmini and D. W. Stephan, *Inorg. Chem.*, **25** (1986) 1222; (c) M. Bosetti, L. De Cola and

- L. M. Vallarino, *Inorg. Chim. Acta*, **105** (1985) 141; (d) S. Gambarotta, S. Arena, C. Floriani and P. F. Zanazzi, *J. Am. Chem. Soc.*, **23** (1984) 1697; (e) H. C. Clark, G. Ferguson, P. N. Kappor and M. Parvez, *Inorg. Chem.*, **24** (1985) 3924; (f) L. Gelmini, L. C. Matassa and D. W. Stephan, *Inorg. Chem.*, **24** (1985) 2585; (g) T. G. Schenck, J. M. Downes, C. R. C. Milne, P. B. MacKenzie, H. Boucher, J. W. Helan and B. Bosnich, *Inorg. Chem.*, **24** (1985) 2334; (h) R. T. Baker, T. H. Tulip and S. S. Wredford, *Inorg. Chem.*, **24** (1985) 1379; (i) C. R. Langrik and B. L. Shaw, *J. Chem. Soc., Dalton Trans.*, (1985) 511; (j) F. H. Hassan, D. P. Markhan, P. G. Pringle and B. L. Shaw, *J. Chem. Soc., Dalton Trans.*, (1985) 279; (k) T. D. Appleton, W. R. Cullen, S. V. Evans, I. Kin and J. Trotter, *J. Organomet. Chem.*, **279** (1985) 5; (l) S. Pal, R. Mukherjee, M. Tomas, L. R. Falvello and A. Chakravorty, *Inorg. Chem.*, **25** (1986) 200; (m) D. L. M. Goodgame, R. W. Rollins and B. Lippert, *Polyhedron*, **4** (1985) 829.
- 2 J. J. Bishop, A. Davison, M. L. Katcher, D. W. Lichtenberg, R. E. Merrill and J. C. Smart, *J. Organomet. Chem.*, **27** (1971) 241.
- 3 C. A. McAuliffe and W. Levason, *Phosphine, Arsine and Stibine Complexes of the Transition Elements*, Elsevier, Amsterdam, 1979.
- 4 D. A. Clemente, G. Pilloni, B. Corain, B. Longato and M. Tiripicchio-Camellini, *Inorg. Chim. Acta*, **115** (1986) L9.
- 5 (a) B. Longato, G. Pilloni, G. M. Bonora and B. Corain, *J. Chem. Soc., Chem. Commun.*, (1986) 1478; (b) B. Longato, B. Corain, G. M. Bonora and G. Pilloni, *Inorg. Chim. Acta*, **137** (1987) 75.
- 6 B. Longato, G. Pilloni, G. Valle and B. Corain, *Inorg. Chem.*, **27** (1988) 956.
- 7 (a) A. W. Rudie, D. W. Lichtenberg, M. L. Katcher and A. Davison, *Inorg. Chem.*, **17** (1978) 2859; (b) T. Hayashi, M. Konishi, Y. Kobori, M. Kumuda, T. Higuchi and K. Hirotsu, *J. Am. Chem. Soc.*, **106** (1984) 158; I. R. Butler, W. R. Cullen, T. J. Kim, S. J. Retting and J. Trotter, *Organometallics*, **4** (1985) 972; (c) K. R. Mann, W. H. Morrison, Jr. and D. N. Hendrickson, *Inorg. Chem.*, **13** (1974) 1180.
- 8 U. Casellato, D. Ajò, G. Valle, B. Corain, B. Longato and R. Grazioni, *J. Crystallogr. Spectrosc. Res.*, **18** (1988) 593.
- 9 (a) D. M. Adams, *Metal-Ligand and Related Vibrations*, E. Arnold, London, 1967; (b) K. Nakamoto, *Infrared Spectra of Inorganic and Coordination Compounds*, Wiley, New York, 2nd edn., 1970.
- 10 M. M. Rhomer, A. Veillard and M. H. Wood, *Chem. Phys. Lett.*, **29** (1979) 466.
- 11 (a) P. E. Garron, *Chem. Rev.* **81** (1981) 229; (b) W. E. Hill, C. A. McAuliffe, *Coord. Chem. Rev.*, **55** (1984) 31; (c) R. C. Goal, W. P. Henry, N. K. Jha, *Inorg. Chem.*, **21** (1982) 2551; (d) D. Dakternieks, C. L. Rolls, *Inorg. Chim. Acta*, **87** (1984) 5; (e) R. Colton, D. Dakternieks, *Aust. J. Chem.*, **33** (1980) 1677.
- 12 H. Van Dam and A. Oskam, in J. A. Melson and B. N. Figgis (eds.), *Transition Metal Chemistry*, Marcel Dekker, New York, 1985.
- 13 S. Evans, M. L. H. Green, B. Jewitt, G. H. King and A. F. Orchard, *J. Chem. Soc., Faraday Trans.*, **68** (1972) 1847.
- 14 T. P. Debies and J. W. Rabalais, *Inorg. Chem.*, **13** (1974) 308.
- 15 Ch. J. O'Connor, Magnetochemistry – advances in theory and experimentation, in S. J. Lippard (ed.), *Progress in Inorganic Chemistry*, Vol. 29, Wiley, New York, 1982, pp. 208–211.
- 16 G. Wilkinson (ed.), *Comprehensive Organometallic Chemistry – The Synthesis, Reactions and Structures of Organometallic Compounds*, Vol. 4, Pergamon, Oxford, 1982, p. 481, and refs. therein.
- 17 S. Riyer, D. R. Tueting and N. E. Schore, *J. Organomet. Chem.*, **320** (1987) 339; N. E. Shore, L. S. Benner and B. E. LaBelle, *Inorg. Chem.*, **20** (1981) 3200.